

Foamer 50

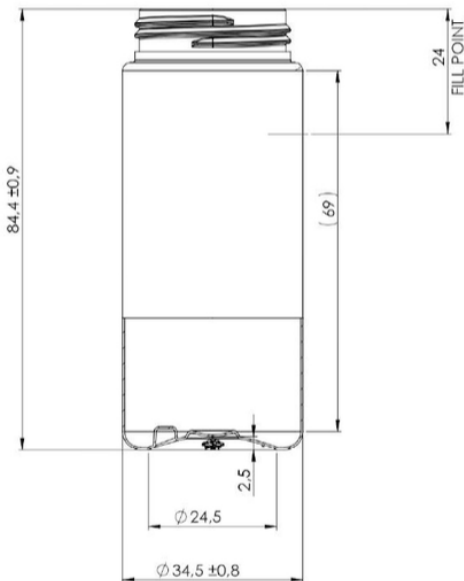

Food contact statement

We hereby confirm that this product complies with the requirements of the European legislation (EU) no 10/2011 and all its amendments for plastics used in contact with food.

[Request Sample](#)

General info

Item no. (SKU):	LS1140420120-1
Family / Range:	Foamer
Capacity:	50ml
Neck:	43/400
Weight:	11
Shape:	Round
Material:	PET / RPET
Colour:	All Colours Available
Print Areas:	N/A
Country of Origin:	Lithuania

Packaging Info

Packed in Boxes

Box Dimensions (mm):	594 x 394 x 448
Quantity per box (pcs):	415
Boxes per pallet (pcs):	20
Quantity per pallet (pcs):	8300
Net weight (kg):	199
Gross weight (kg):	215
Pallet height (mm):	2400

Packed in PE bags on trays (Half pallet)

Tray dimensions (mm):	1200 x 800 x 50
Quantity per tray (pcs):	832
Quantity per PE bag (pcs):	104
PE bags per tray (pcs):	8
Trays per pallet (pcs):	5
Quantity per pallet (pcs):	4160
Net weight (kg):	92
Gross weight (kg):	106
Pallet height (mm):	1200

Storage

Please be aware that these products are handled and stored correctly in order to ensure the safety and quality of our products. When storing this product, please avoid excessive force and storage above 40 degrees Celsius (86 degrees Fahrenheit).